

Wireless **SOLAR SYNC**

Wireless ET Sensor for Compatible Hunter Controllers

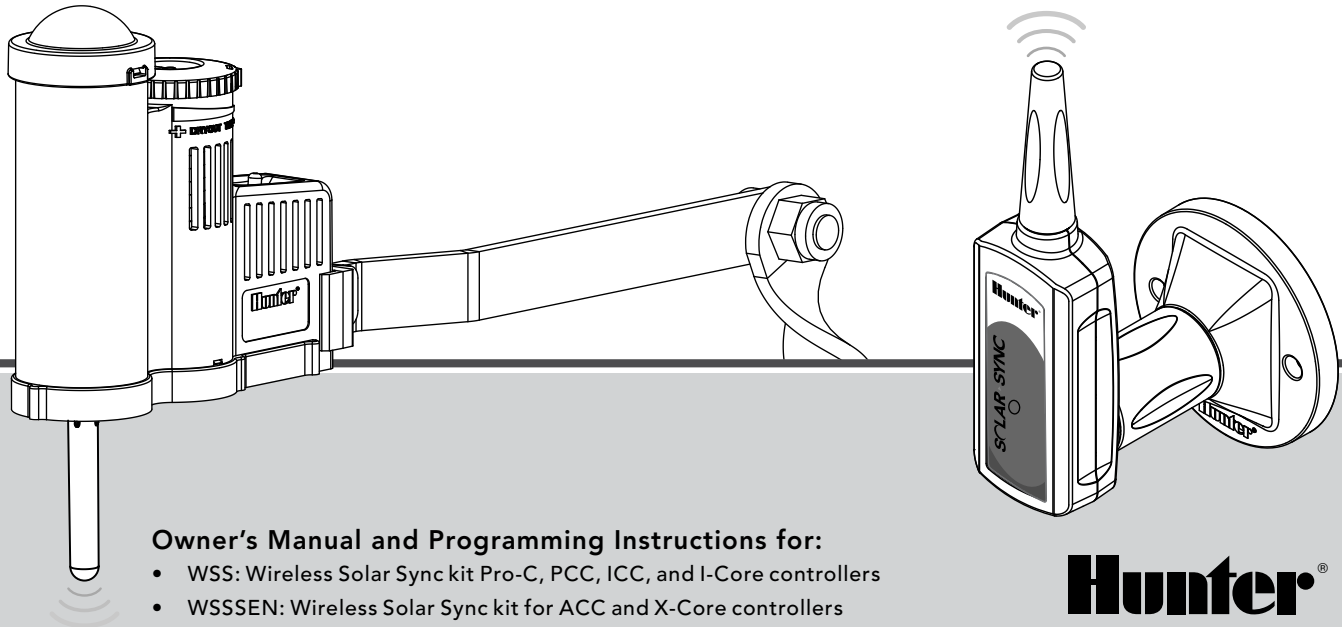

Owner's Manual and Programming Instructions for:

- WSS: Wireless Solar Sync kit Pro-C, PCC, ICC, and I-Core controllers
- WSSSEN: Wireless Solar Sync kit for ACC and X-Core controllers

Hunter[®]

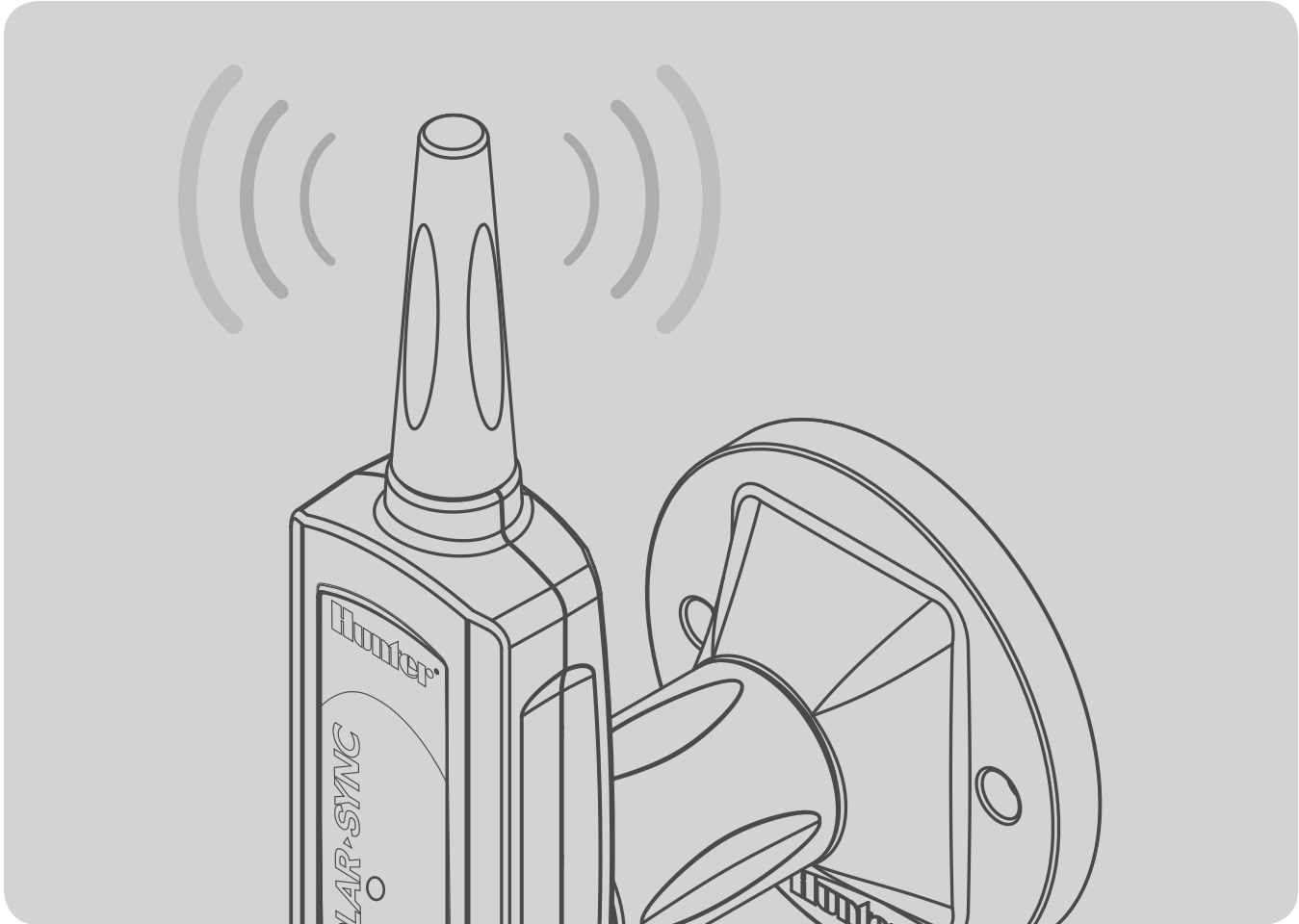

TABLE OF CONTENTS

| | | | |
|--|----|---|----|
| INTRODUCTION | 2 | ADDRESSING WIRELESS RECEIVER/SENSOR | 13 |
| SYSTEM OVERVIEW AND OPERATION | 2 | PROGRAMMING CONTROLLER RUN TIMES | 14 |
| SENSOR DETAILS | 4 | PROGRAMMING THE SOLAR SYNC MODULE | 15 |
| Installing the Sensor | 4 | CALIBRATION / SETUP PERIOD | 18 |
| Click Operation | 5 | TROUBLESHOOTING GUIDE | 19 |
| Bypassing the Sensor | 5 | SPECIFICATIONS / DIMENSIONS / FCC NOTICE | 21 |
| Maintaining the Sensor..... | 5 | Controller Compatibility | 21 |
| CONNECTING TO THE CONTROLLER | 6 | Specifications | 21 |
| Installing and Wiring the Module | 6 | Dimensions..... | 21 |
| Pro-C Conventional Controller (PCC Series) | 7 | FCC Notice..... | 22 |
| Pro-C Controller (PC Series) | 9 | Industry of Canada Notice | 23 |
| ICC Controller | 10 | CE and Australia Notice | 23 |
| I-Core Controller | 11 | | |
| X-Core Controller | 12 | | |
| ACC Controller..... | 12 | | |

INTRODUCTION

The Solar Sync is a sensor system that, when connected to a compatible Hunter controller, will automatically adjust your controller watering based upon changes in local climate conditions. The Solar Sync utilizes a solar and temperature sensor to measure on-site weather conditions used to determine evapotranspiration (ET), or the rate at which plants and turf use water. In addition, Solar Sync includes a Hunter Rain-Clik™ and Freeze-Clik™ sensor that will shut down your irrigation system when it rains and/or during freezing conditions.

A small module connects the sensor to the controller and will automatically increase or decrease watering run times based on changes in weather. The result is a new water-efficient irrigation product that promotes water conservation and healthier plants. You simply program your controller like you normally would, and the Solar Sync takes over from there, eliminating the need to manually adjust your watering schedule.

SYSTEM OVERVIEW AND OPERATION

The Wireless Solar Sync System is simply and easily installed on any compatible Hunter Irrigation controller (see Owner's Manual to verify compatibility). The Wireless Solar Sync Sensor measures solar radiation and temperature and calculates the daily evapotranspiration (ET) factor for irrigation. This represents the amount of water lost by the plants due to local climate conditions, which needs to be replaced by irrigation. The Wireless Solar Sync also includes Hunter Rain-Clik™ and Freeze-Clik® sensors that will automatically shut down the irrigation system during rain events or freezing conditions.

Enter a mid summer watering program in your controller per the programming instructions in the Owner's Manual provided with your controller. The Wireless Solar Sync Sensor sends weather data and applies it daily to the controller's water schedule by adjusting the controller through the seasonal adjust feature.

This Owner's Manual applies to the following kits:

- WSS: Wireless Solar Sync kit for Hunter Pro-C, PCC, ICC, and I-Core controllers
- WSSSEN*: Wireless Solar Sync kit for Hunter ACC and X-Core controllers

*Note that WSSSEN **does not** include the Solar Sync Module. The ACC and X-Core controllers have the Solar Sync software built in and do not require the Solar Sync Module. Therefore, the WSSSEN should be used with the ACC and X-Core Controllers.

SYSTEM OVERVIEW AND OPERATION



Wireless Solar Sync Receiver

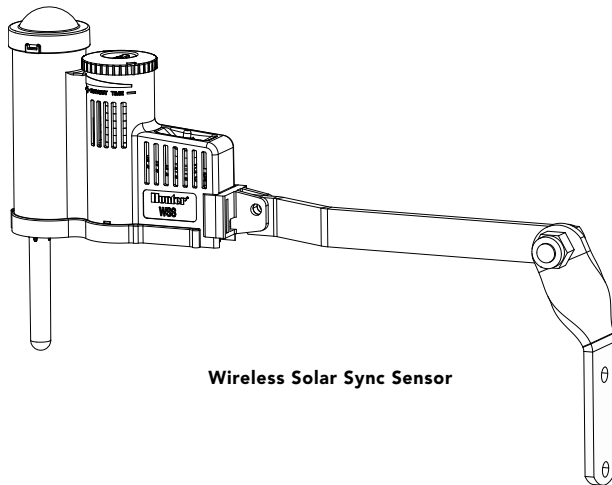

Wireless Solar Sync Sensor

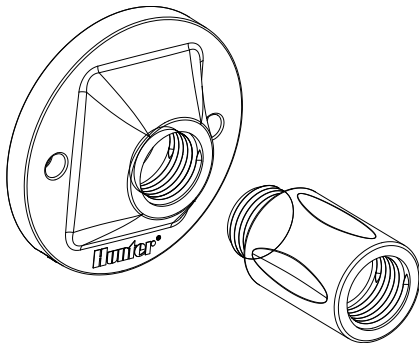

Wall Mount Bracket

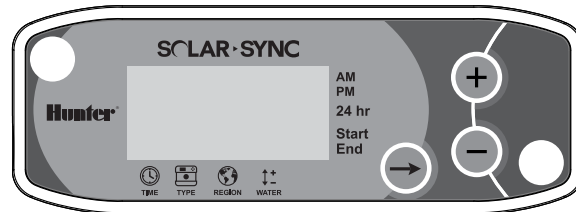

Solar Sync Module

SENSOR DETAILS

Installing the Sensor

Using the screws provided, mount the Solar Sync sensor on any surface where it will be exposed to unobstructed sun and rainfall, but not in the path of sprinkler spray. The sensor needs to be oriented upright and the swivel bracket can be moved for mounting on angled surfaces. Loosen the locknut and screw before swiveling the bracket and then retighten.

 **Note:** The Wireless Solar Sync Sensor is designed to operate to a maximum distance of 800 feet (228 m) from the Wireless Receiver.

 **Note:** Place Solar Sync where it can receive full sun.

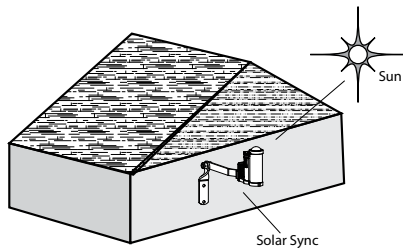

The Sensor Gutter Mount can also be used as an optional mounting method. The Sensor Gutter Mount (SGM) allows the Sensor to be mounted directly to the edge of a gutter. Install the SGM on the Sensor by removing the extension arm supplied with your Sensor and reinstalling SGM in its place. Position the SGM on the edge of the gutter and secure by twisting the thumb screw.

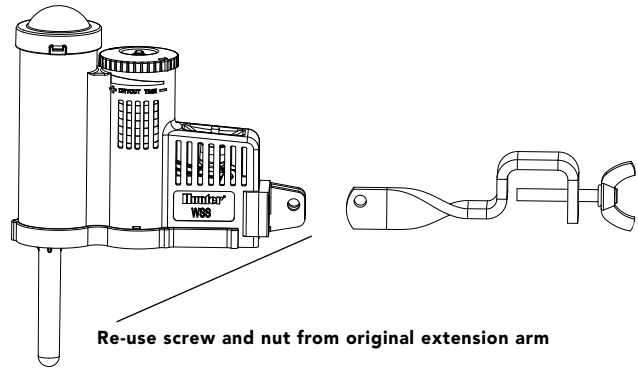

SENSOR DETAILS

Click Operation

The Rain-Click™ will keep the irrigation from starting or continuing during rainfall. No adjustment or calibration is required for the Rain-Click™ sensor. The Rain-Click™ uses patented Quick Response™ technology that will shut the system off during the first few minutes of rain. The only adjustment that is necessary is the vent ring that will either slow down or speed up the time at which the sensor dries out and the system is turned back on. Opening the vent will speed up the dry out time and closing the vents will slow down dry out time.

In addition, the Solar Sync's built-in temperature sensor provides system shutdown when freezing conditions occur. At approximately 37° F/3° C and below the Solar Sync module will command the controller to shut down. A "sensor off" indication will be displayed on your controller when the sensor is active. When temperatures rise above 37° F/3° C, automatic irrigation will be activated at the next scheduled start time.

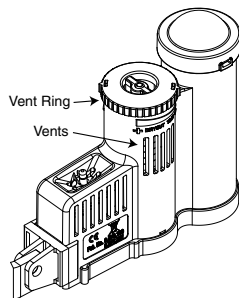

Bypassing the Sensor

If the Rain Sensor or Freeze Sensor is preventing system operation, **SENSOR OFF** will be displayed on the controller's display. Simply move the Bypass switch on the controller to **BYPASS** and the Solar Sync's Rain and Freeze Sensor will be bypassed. This allows you to operate your system. The Solar Sync will continue to make adjustments to your controller's watering schedule.

The controller's Rain Sensor switch should be in the **ACTIVE** position for the Rain Sensor and Freeze Sensor to interrupt watering during rainy and/or freezing conditions.

Maintaining the Sensor

The Solar Sync sensor is designed for outdoor use, but must be kept clean to function correctly. Wiping the clear dome covering the solar radiation sensor every 6 months is recommended. Do not use harsh chemicals or abrasives on the clear dome.

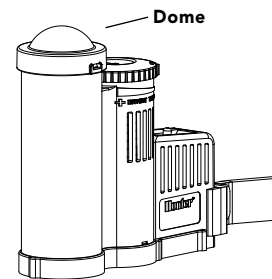

CONNECTING TO THE CONTROLLER

Installing and Wiring the Module

Begin by activating the CR2032 backup battery (used for date/time backup in the event of a power outage) by pulling the battery insulator at the bottom of the module. The expected battery life is ten years. If the battery requires replacement, the battery compartment is located on the back of the Solar Sync module. Remove the cover and install the battery with the positive side (+) of the battery visible, facing toward you. Replace the battery cover. Replace battery with CR2032 type battery only. Use of another battery may present a risk of fire or explosion.



Note: Battery may explode if mistreated. Do not recharge, disassemble or dispose of in fire.

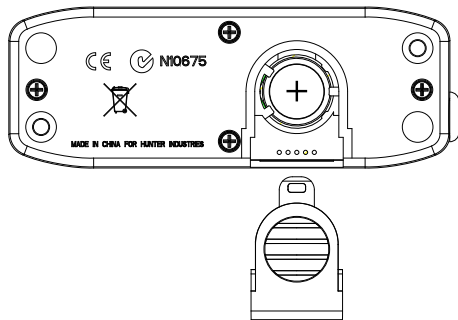

The Solar Sync module is designed to be wall-mounted next to the irrigation controller. A rubber cover is provided for outdoor installations to protect the module from the weather. Use two anchors or self-tapping screws to secure the module to the wall. Place the rubber cover mounting tab behind the module before screwing the module to the wall.

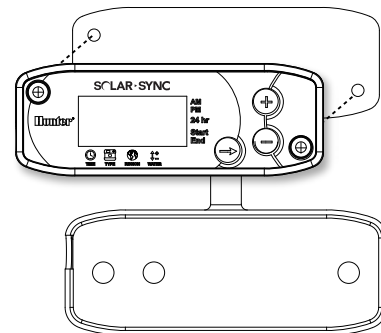

Note: If you are installing Solar Sync on an ACC or X-Core Controller, the Solar Sync Module is not required. For the ACC or X-Core controllers, the *WSSSEN* kit should be used, as it does not include the Module. (See the controller's owner's manual for more details.)

CONNECTING TO THE CONTROLLER

Pro-C Conventional Controller (PCC Series)

The PCC series version of the Pro-C is designed so that the Solar Sync module can be installed inside the controller cabinet. Use the two screws provided to mount the module as shown in the diagram.

1. Connect the **red** wire from the Solar Sync module to the AC1 terminal
2. Connect the **white** wire from the Solar Sync module to the AC2 terminal
3. Connect the **blue** wire from the Solar Sync module to the REM terminal
4. **Remove** the flat metal jumper from the two SEN terminals
5. Connect the **yellow** wire to one of the SEN terminals
6. Connect the **orange** wire to the other SEN terminal

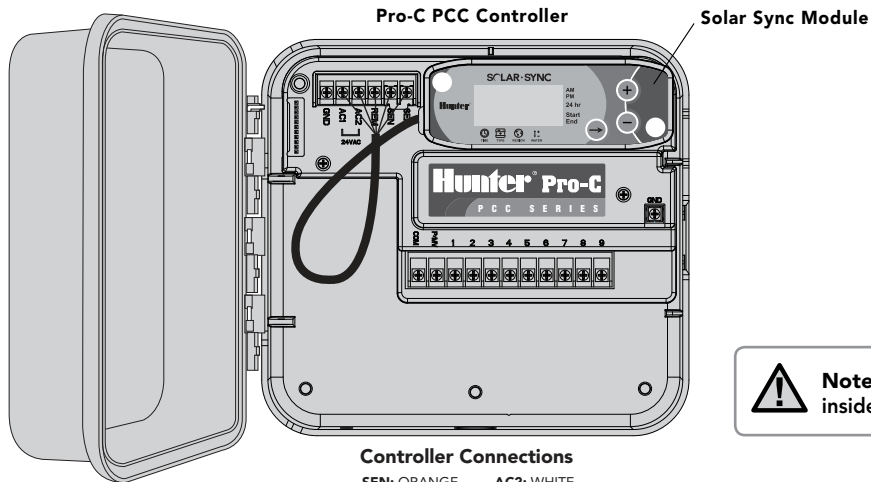

Controller Connections

SEN: ORANGE AC2: WHITE
SEN: YELLOW AC1: RED
REM: BLUE



Note: For Pro-C PCC Series controllers, there are provisions inside the controller to mount the Solar Sync module.

CONNECTING TO THE CONTROLLER

Pro-C Conventional Controller (PCC Series)

Mount the Wireless Receiver on the controller cabinet using an available knock out and secure with the supplied conduit nut. Or, use the supplied brackets to mount the Wireless Receiver on the wall. Depending on the installation, the supplied 1.5" (3.8 cm) extender may be required (shown below). Route the wires from the Wireless Receiver into the controller cabinet.

1. Make sure power to the controller is turned off
2. Connect the **black** Receiver wire to the black Module wire
3. Connect the **green** Receiver wire to the green Module wire
4. Initialize communication by following steps outlined in "Addressing Wireless Receiver/Sensor" section on page 13

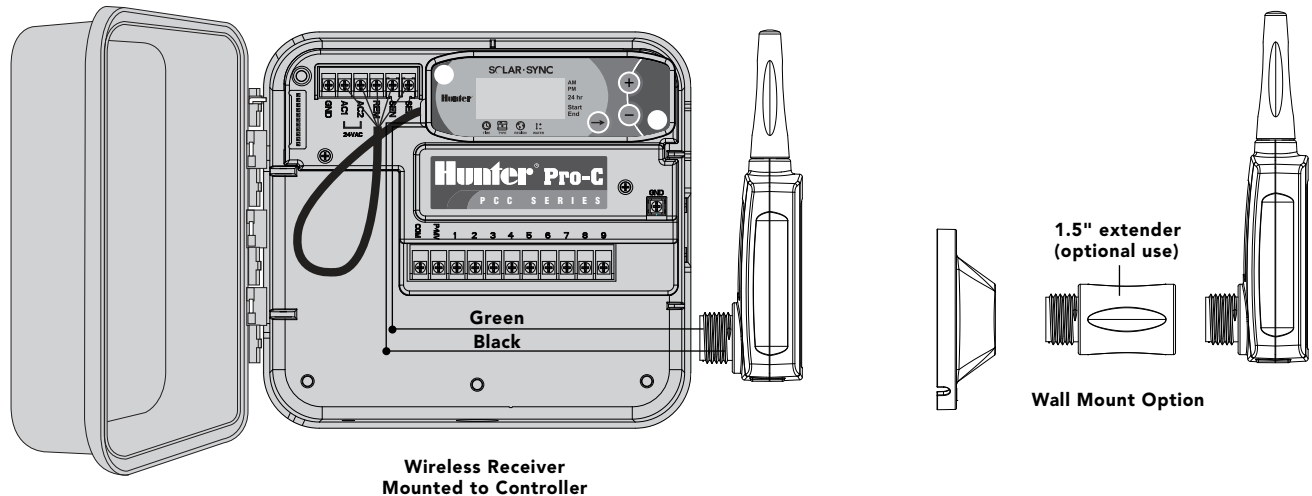

CONNECTING TO THE CONTROLLER

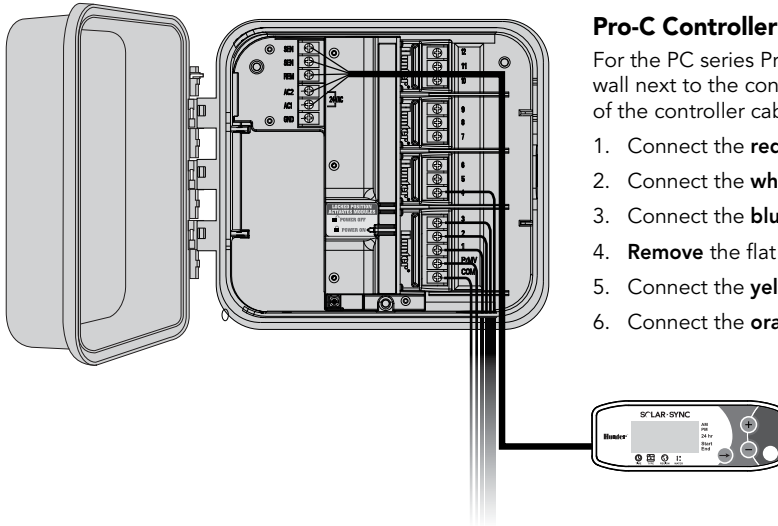

Pro-C Controller (PC Series)

For the PC series Pro-C Modular controller, mount the Solar Sync module on the wall next to the controller cabinet. There is an additional knockout on the right side of the controller cabinet to route Solar Sync wires into and out of the cabinet.

1. Connect the **red** wire from the Solar Sync module to the AC1 terminal
2. Connect the **white** wire from the Solar Sync module to the AC2 terminal
3. Connect the **blue** wire from the Solar Sync module to the REM terminal
4. **Remove** the flat metal jumper from the two SEN terminals
5. Connect the **yellow** wire to one of the SEN terminals
6. Connect the **orange** wire to the other SEN terminal

Mount the Wireless Receiver on the controller cabinet using the options described on page 8. Due to the position of the power module in the Pro-C controller, a more convenient option may be to mount the Wireless Receiver to the wall using the Wall Mount Bracket.

1. Make sure power to the controller is turned off
2. Connect the **black** Receiver wire to the black Module wire
3. Connect the **green** Receiver wire to the green Module wire
4. Initialize communication by following steps outlined in “Addressing Wireless Receiver/Sensor” section on page 13

CONNECTING TO THE CONTROLLER

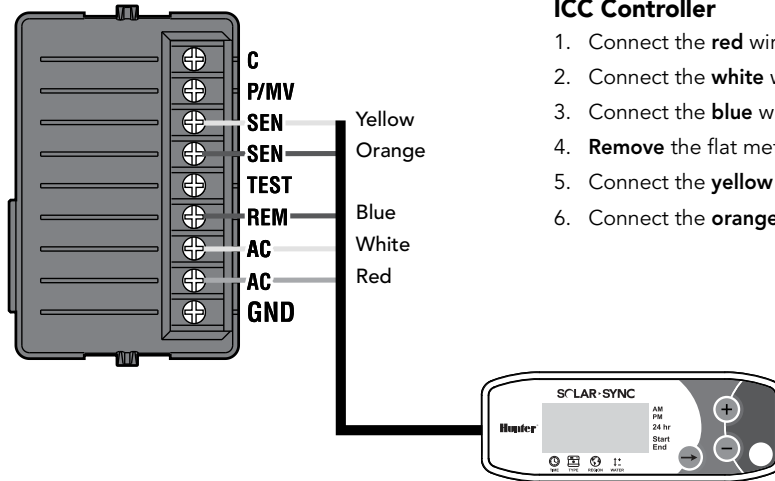

ICC Controller

1. Connect the **red** wire from the Solar Sync module to the AC1 terminal
2. Connect the **white** wire from the Solar Sync module to the AC2 terminal
3. Connect the **blue** wire from the Solar Sync module to the REM terminal
4. **Remove** the flat metal jumper from the two SEN terminals
5. Connect the **yellow** wire to one of the SEN terminals
6. Connect the **orange** wire to the other SEN terminal

Mount the Wireless Receiver on the controller cabinet using an available knock out and secure with the supplied conduit nut, similar to the Pro-C installation shown on page 8. Or, use the supplied brackets to mount the Wireless Receiver on the wall. Depending on the installation, the supplied 1.5" (3.8 cm) extender may be required. Route the wires from the Wireless Receiver in to the controller cabinet.

1. Make sure power to the controller is turned off
2. Connect the **black** Receiver wire to the black Module wire
3. Connect the **green** Receiver wire to the green Module wire
4. Initialize communication by following steps outlined in "Addressing Wireless Receiver/Sensor" section on page 13

CONNECTING TO THE CONTROLLER

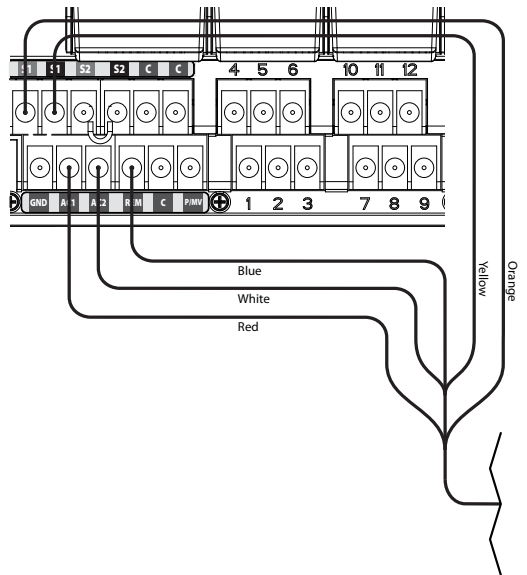

I-Core Controller

1. Connect the **red** wire from the Solar Sync module to the AC1 terminal
2. Connect the **white** wire from the Solar Sync module to the AC2 terminal
3. Connect the **blue** wire from the Solar Sync module to the REM terminal
4. **Remove** the flat metal jumper from the two SEN terminals
5. Connect the **yellow** wire to one of the SEN terminals
6. Connect the **orange** wire to the other SEN terminal

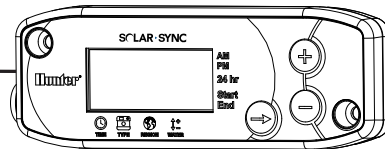

Solar Sync Module

Mount the Wireless Receiver on the controller cabinet using an available knock out and secure with the supplied conduit nut. Or, use the supplied brackets to mount the Wireless Receiver on the wall. Depending on the installation, the supplied 1.5" (3.8 cm) extender may be required. Route the wires from the Wireless Receiver in to the controller cabinet.

1. Make sure power to the controller is turned off
2. Connect the **black** Receiver wire to the black Module wire
3. Connect the **green** Receiver wire to the green Module wire
4. Initialize communication by following steps outlined in "Addressing Wireless Receiver/Sensor" section on page 13

CONNECTING TO THE CONTROLLER

X-Core Controller

The X-Core Controller is programmed with Solar Sync technology and, therefore, does not require the use of the Solar Sync module. Simply mount the Wireless Receiver on the controller cabinet using an available knock out and secure with the supplied conduit nut. Or, use the supplied brackets to mount the Wireless Receiver on the wall, similar to the Pro-C installation shown on page 8. Depending on the installation, the supplied 1.5" (3.8 cm) extender may be required. Route the wires from the Wireless Receiver in to the controller cabinet.

1. Make sure power to the controller is turned off
2. Connect the **black** Receiver wire to the "SEN" Terminal location (it does not matter which "SEN" terminal is used)
3. Connect the **green** Receiver wire to the other "SEN" terminal location

See X-Core owner's manual for further details.*

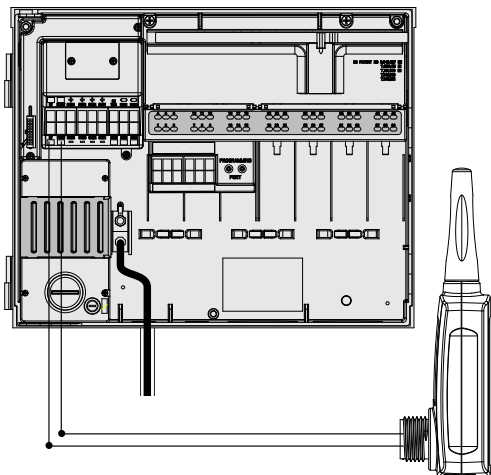
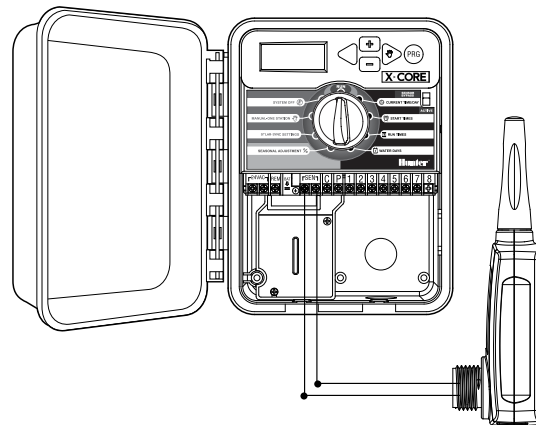

ACC Controller

The ACC Controller is programmed with Solar Sync technology and, therefore, does not require the use of the Solar Sync module. Simply mount the Wireless Receiver on the controller cabinet using an available knock out and secure with the supplied conduit nut. Or, use the supplied brackets to mount the Wireless Receiver on the wall, similar to the Pro-C installation shown on page 8. Depending on the installation, the supplied 1.5" (3.8 cm) extender may be required. Route the wires from the Wireless Receiver in to the controller cabinet.

1. Make sure power to the controller is turned off
2. Connect the **black** Receiver wire to the black "ET" terminal on the master module
3. Connect the **green** Receiver wire to the green "ET" terminal on the master module

See ACC owner's manual for further details.*



Note: *The X-Core and ACC controllers have the Solar Sync software built in. Please see the controllers' owner's manuals for Solar Sync programming instructions.

ADDRESSING WIRELESS RECEIVER/SENSOR

The Wireless Solar Sync Receiver and Sensor are already paired with the same frequency for an easy installation. When installed, the wireless Receiver will automatically go into a "search" mode looking for the signal from its paired Sensor. However, it is a good idea to initialize communication manually between the wireless Receiver and Sensor during installation to verify correct signal transmission.

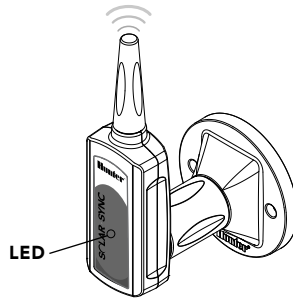

To initialize communication manually between wireless Receiver and Sensor:

- After Receiver's green and black wires have been connected (see "Connecting To The Controller" section), restore power to the controller
- The red LED in the center of the wireless Receiver will turn on and stay solid for 10 seconds, indicating that it is in search mode, searching for a signal from a wireless sensor
- While the red LED is solid and the wireless Receiver is in search mode, press and hold the spindle on the wireless Sensor. The LED on the wireless Receiver will blink 4 times and then turn off, indicating that the signal from the wireless Sensor has been acknowledged.

To Validate Receiver/Sensor Communication or Re-address:

- Press and hold the spindle on the wireless Sensor
- The LED on the wireless Receiver will blink 2 times, confirming that the Receiver is addressed to the Sensor properly



Note: In the event of a power outage (or any other reason when the Receiver loses radio contact with the wireless Sensor) the Receiver will automatically go into search mode to re-establish communication with the Sensor once power is restored. However, when power is restored the controller will automatically go into rain shut off mode until communication with the Sensor is re-established, which may be up to 60 minutes (maximum). Performing the steps listed above to validate Receiver/Sensor communication will remove the controller from rain shut off mode and will return to its programmed irrigation schedule.

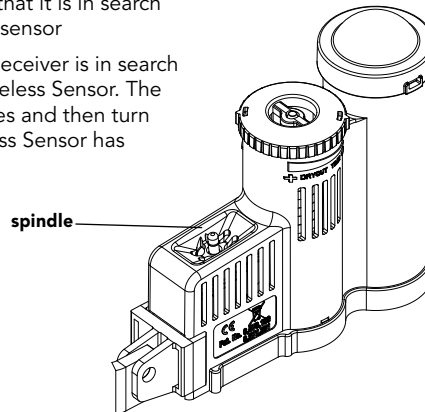

PROGRAMMING CONTROLLER RUN TIMES

Program your Hunter controller as specified in the Owner's Manual.

When setting station run times, enter the time that would normally be programmed during the peak summer watering season. The Solar Sync is designed to adjust all run times daily based upon on-site weather conditions. This is done through the seasonal adjustment feature on your controller. It is recommended that all programming be conducted with the controller Seasonal Adjustment set at 100%.



Note: Set station run times for peak summer watering with seasonal adjustment set at 100%.

PROGRAMMING THE SOLAR SYNC MODULE

The Solar Sync is simple to program. Only a few initial steps are necessary to program the module. When power is initially turned on, the display will show the time of day. Pressing the → button will sequence through the programming functions on the module. An arrow along the bottom of the display will indicate the function being programmed.

If using the Solar Sync with the ACC or X-Core Controllers, consult the controller owner's manual for programming details. (ACC and X-Core controllers do not use the Solar Sync module.)



Current Time

Press the → button until the arrow is displayed over the  icon. The time of day will be flashing. Use the + or - button to set the current time. The arrow to the right of the display indicates AM or PM.



Note: 24 hour mode will only be enabled with a 50 Hz power input.

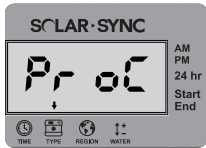

Controller Type

Press the → button until the arrow is displayed over the  icon. Use the + or - button to select the correct Hunter controller.

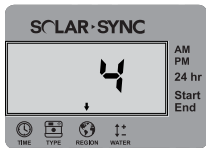

Region

For accurate measurements, the Solar Sync module needs to be programmed for the typical ET (average July ET) for your region. Use the table on the next page to determine your region. Press the → button until the arrow is displayed over the  icon. Use the + or - button to select your region (regions 1 through 4).

PROGRAMMING THE SOLAR SYNC MODULE

The table will assist you in identifying the type of region you live in. There are four basic ET regions, each with descriptions of the region, along with typical ET and temperature characteristics. It is recommended that, if possible, the region be chosen based upon average July ET or peak summer ET (inches/mm per day).

Use the following table for choosing your region (reference below). You can use **A**, **B** or **C** to help you choose which region is best for your area:

A: Based upon the ET of your region using the **average** July ET or peak summer ET (inches/mm per day). This is the preferred option when selecting your region

B: Based upon the temperature for your region using the **average** July or the driest month high temperature (not the highest temperature for July)

C: Based upon the general description of your region

IF ANY OF THE CHOICES IN THE ROWS APPLY TO YOUR SITUATION, THEN THAT IS YOUR REGION SETTING CHOICE.

| | A | B | C |
|-----------------|--|---|--|
| Region 1 | If the average July ET is < 0.17" (4.3 mm) per day | If the average temperature for July is 65°–75° (18°C – 24°C) | <ul style="list-style-type: none"> • U.S. Northern States • Coastal Regions |
| Region 2 | If the average July ET is 0.18" – 0.23" (4.6 mm – 5.8 mm) per day | If the average temperature for July is 75°– 85° (24°C – 29°C) | <ul style="list-style-type: none"> • Mountains • U.S. Northern Inland States |
| Region 3 | If the average July ET is 0.24" – 0.29" (6.1 mm – 7.4 mm) per day | If the average temperature for July is 85°– 95° (29°C – 35°C) | <ul style="list-style-type: none"> • U.S. Southern States • Inland/High Desert |
| Region 4 | If the average July ET is > 0.30" (7.6 mm) per day | If the average temperature for July is 95°– 105° (35°C – 41°C) | <ul style="list-style-type: none"> • Deserts |

* For Southern hemisphere locations, use the month of January.

PROGRAMMING THE SOLAR SYNC MODULE

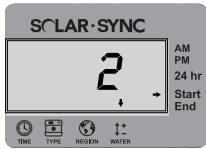

Watering Adjustment ↑↓

If you find that your landscape is “wetter” or “drier” than it should be, a watering adjustment function is provided to adjust watering equally to all stations. Use the → button on the module until the arrow is displayed over the ↑↓ icon. Use the + or - button to increase or decrease the amount of watering scaled 1 to 10 (1 for less water and 10 for more water). Hunter recommends observing performance carefully over the first weeks of operation before adjusting the watering.



Note: If an individual zone is “wetter” or “drier” than the rest of the system, simply increase or decrease the amount of run time on the controller.



No Water Window

If required, the Solar Sync offers a **no water window** capability that prevents any irrigation from occurring during a specific period of the day. The No Water Window is a hidden feature. Press and hold the → button on the module for 5 seconds to program the No Water Window.

An → will be flashing at Start along the right side of the display. Use the + or - button to adjust the time you would like the no watering period to start. Pressing the → button again will display an arrow flashing at End. Use the + or - button to adjust the time you would like the no watering period to end.

CALIBRATION / SETUP PERIOD

After Solar Sync has been installed and programmed, it is recommended to allow the system to run for a few days at the initial setting. Because of the variety in site conditions (including sensor location, amount of direct sunlight available to the sensor, reflective heat from surrounding structures, etc), **the initial setting may require adjustment in order to arrive at the desired performance.** The calibration of the Solar Sync to a particular site can easily be accomplished by adjusting the Region and/or Water Adjustment settings. The instructions below outline this process:

1. Install Solar Sync sensor and program the module (as described in pages 10–12)
2. Allow system to operate at initial settings for a minimum of 3 days
3. Observe the Seasonal Adjust on the controller. If the Seasonal Adjust amount appears to be lower or higher than expected for that time of year, the Solar Sync settings need to be adjusted.
 - a. **Seasonal Adjust too low:** Make sure controller dial is in the “Run” position. Increase the value on the Water Adjustment scale (10 is max). Once the setting is changed, the controller will immediately be updated with the new Seasonal Adjust %. Increase the Water Adjustment setting until the desired Seasonal Adjust % is shown. **If you max out the Water Adjustment scale at 10 and still require more Seasonal Adjust, move down to the next lower Region (from Region 4 to 3, for example).**
 - b. **Seasonal Adjust too high:** Make sure controller dial is in the “Run” position. Decrease the value on the Water Adjustment scale (default setting is 5). Once the setting is changed, the controller will immediately be updated with the new Seasonal Adjust %. Decrease the Water Adjustment setting until the desired Seasonal Adjust % is shown. **If you minimize the Water Adjustment scale down to 1 and still require a reduction in Seasonal Adjust, move up the next Region (from Region 2 to 3, for example).**

Station Run Times: It is important to understand that Solar Sync provides a global seasonal adjustment to the controller. This means that all station run times will be modified by the seasonal adjust percentage shown. When programming the controller, the run times should be entered that represent peak season watering schedules. If the Solar Sync is adjusting to the appropriate seasonal adjust value but the run time for a particular station appears to be too long/short, adjust the station run time in the controller program. **When adjusting station run times, make sure the seasonal adjust valve is set to 100%.**

TROUBLESHOOTING GUIDE

| Problem | Causes | Solutions |
|---|---|---|
| Controller shows "ERR" in display | <ul style="list-style-type: none"> • Module wires not properly connected to controller terminal | Check the connection between module and controller and compare to wiring diagram in System Installation section of Owner's Manual |
| Solar Sync module shows "ERR" | <ul style="list-style-type: none"> • Connection between module and sensor faulty | Check connection between module and sensor (green and black wires) |
| Solar Sync Module shows "SERR" in display | SERR indicates Sensor Error. Communication has been lost between the Wireless Sensor and Wireless Receiver | Follow steps to re-address Wireless Sensor on page 13. Once communication between Wireless Sensor and Wireless Receiver is re-established, the SERR will no longer show in the Solar Sync Module display. |
| Seasonal Adjust seems low | <ul style="list-style-type: none"> • Region too high • Water Adjustment Setting too low • Location of Sensor does not allow for full sun | Make sure controller dial is in "RUN" position. Increase the value on the Water Adjustment scale (the default setting is 5). If you max out the Water Adjustment scale at 10 and still require more seasonal adjustment, move down one Region (from 4 to 3, for example) and start at Water Adjustment setting 5. Solar Sync will immediately update the Seasonal Adjust on the controller. If it is still too low, repeat the adjustment until the desired seasonal adjust is showing on the controller. |
| Seasonal Adjust seems high | <ul style="list-style-type: none"> • Region too low • Water Adjustment setting too high | Make sure controller dial is in "RUN" position. Decrease value of the Water Adjustment setting. If you minimize the Water Adjustment scale at 1 and still require a reduced seasonal adjustment, move down up one Region (from 2 to 3, for example) and start at Water Adjustment setting 5. Solar Sync will immediately update the Seasonal Adjust on the controller. If it is still too high, repeat the adjustment until the desired seasonal adjust is showing on the controller. |

TROUBLESHOOTING GUIDE

| Problem | Causes | Solutions |
|---|---|---|
| Controller's Seasonal Adjustment is reset to 100% and does not change | Communication has been lost between the Wireless Sensor and Wireless Receiver. The "SERR" error message will be shown in the Solar Sync Module display (if used). If communication is lost the Solar Sync sends a safe 100% seasonal adjustment to the controller and shows the error message on the Solar Sync Module display. | Follow steps to re-address Wireless Sensor on page 13. Once communication between Wireless Sensor and Wireless Receiver is re-established, the SERR will no longer show in the Solar Sync Module display. |
| Rain or Freeze shutoff not activating | <ul style="list-style-type: none"> • Rain Sensor Bypass Switch on Controller set to "Bypass" • Jumper Clip still on controller wiring terminal | Set the Controller Bypass Switch in the "Active" position. Remove jumper clip. |
| Run times for a particular station are too short/too long | <ul style="list-style-type: none"> • Program Run Time too long/too short | Solar Sync provides a global seasonal adjustment to the controller. If a particular station has run times too long or too short, make the appropriate adjustment to the program in the controller. |
| Solar Sync still sending Seasonal Adjust when Controller Bypass switch in the "Bypass" position | <ul style="list-style-type: none"> • Solar Sync's automated seasonal adjustment cannot be de-activated by the Bypass switch • The Bypass switch only controls the Rain/ Freeze shutoff function of the Solar Sync | |

Hunter Technical Service: 1-800-733-2823 or www.hunterindustries.com/Support/Ask_Expert/default.htm

SPECIFICATIONS / DIMENSIONS / FCC NOTICE

Controller Compatibility

The Solar Sync is designed for use with Hunter controllers that are enabled with a Smart Port connection.

WSS: Wireless Solar Sync kit, for use with Hunter Pro-C, PCC, ICC, and I-Core Controllers

WSSSEN: Wireless Solar Sync kit (no module included), for use with Hunter ACC and X-Core controllers

Specifications

- Power Input: 24 VAC 50/60 HZ (from controller)
- Current draw: 25 mA at 24 VAC
- Non Volatile Memory
- Replaceable 10 year lithium battery: CR2032 (in module)
- 10 year battery (wireless)
- Maximum distance module from controller: 6 ft (2 m)
- Maximum distance Receiver to Module: 6 ft (2 m)
- Maximum distance Sensor to Receiver: 800 ft (228 m)
- Wiring: 18 AWG/1 mm or 20 AWG/0.8 mm diameter minimum from Sensor to Module
- UL Listed
- Direct Burial and UV approved

Dimensions

Sensor:

3" H x 9" W x 1" D
(7.6 cm x 22.9 cm x 2.5 cm)

Module:

1¾" H x 5" W x ⅝" D
(4.4 cm x 12.7 cm x 0.6 cm)

Receiver:

5.5" H x 1.5" W x 1½" D
(14 cm x 3.8 cm x 3.8 cm)

Receiver with Wall Mount Bracket:

6⅞" H x 2¾" W x 3½" D
(15.5 cm x 7 cm x 8.9 cm)

SPECIFICATIONS / DIMENSIONS / FCC NOTICE

FCC Notice

Transmitter FCC ID : M 3USSW

This device complies with FCC rules Part 15. Operation is subject to the following two conditions:

1. This device may not cause harmful interference and
2. This device must accept any interference that may be received, including interference that may cause undesired operation

This equipment has been tested and found to comply with the limits for class B digital device, pursuant to part 15 of the FCC Rules. These limits are designed to provide reasonable protection against harmful interference in a residential installation. This equipment generates, uses, and can radiate radio frequency energy and, if not installed and used in accordance with the instructions, may cause harmful interference to radio communications. However, there is no guarantee that interference will not occur in a particular installation. If this equipment does cause harmful interference to radio or television reception, which can be determined by turning the radio equipment off and on, the user is encouraged to try to correct the interference by one or more of the following measures:

- Reorient or relocate the receiving antenna
- Increase the separation between the equipment and receiver
- Connect the equipment into an outlet on a circuit different from that to which the receiver is connected
- Consult the dealer or an experienced radio/TV technician for help

The user is cautioned that changes and modifications made to the equipment without the approval of the manufacturer could void the user's authority to operate this equipment.

| | |
|--------------------------------------|---------------------------------------|
| Trade Name | Wireless Solar Sync |
| Model Number | WSSR |
| Compliance Test Report Number | B00217D4 |
| Compliance Test Report Date | 1/29/2010 |
| Responsible Party | Hunter Industries Incorporated |
| Address | 1940 Diamond St, San Marcos, CA 92078 |
| Telephone | 760-744-5240 |

I, the undersigned, hereby declare that the equipment specified above conforms to the above requirements.

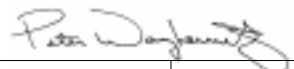
| | |
|---|-------------------------------|
| Signature:  | |
| Place: San Marcos, CA | Full Name: Peter Woytowicz |
| Date: March 22, 2010 | Position: Engineering Manager |

SPECIFICATIONS / DIMENSIONS / FCC NOTICE

Industry of Canada Notice

Sensor - IC: 2772A-SSW

Receiver - IC: 2772A-SSWR

Operation is subject to the following conditions:

- This device may not cause harmful interference and
- This device must accept any interference received, including interference that may cause undesired operation

This class B digital apparatus complies with Canadian ICES-003.

The term IC before the certification/registration number only signifies that the Industry of Canada technical specifications were met.

Operation is subject to the following conditions: 1) this device may not cause interference, and 2) this device must accept any interference, including interference that may cause undesired operation in the device.

CE and Australia Notice

Hunter Industries hereby declares that this remote control device is in compliance with the essential requirements and other relevant provisions of Directive 1999/5/CE.

Declaration of Conformity: We, Hunter Industries Incorporated, 1940 Diamond Street, San Marcos, CA 92078, declare under our own responsibility that the Wireless Solar Sync, model numbers WSSTR and WSSR, to which this declaration refers, conforms with the relevant standards:

Emissions: ETSI EN 300 220-1 V2.1.1
ETSJ EN 300 220-2 V2.1.1
ETSI EN 301 489-1 (per EN55022)
EN 61000-3-2
EN 61000-3-3

Immunity: ETSI EN 301 489-1 V1.4.1
(per IEC61000-4-2 through IEC61000-4-6, and IEC61000-4-11)

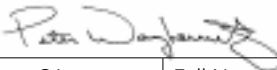
| | |
|---|-------------------------------|
| Signature:  | |
| Place: San Marcos, CA | Full Name: Peter Woytowicz |
| Date: March 22, 2010 | Position: Engineering Manager |

Hunter®

Hunter Industries Incorporated • The Irrigation Innovators
1940 Diamond Street • San Marcos, California 92078 USA
www.hunterindustries.com

© 2010 Hunter Industries Incorporated

LIT-520 A 9/10